

GP-2710 Intelligent Pressure Sensor

Features

- ✓ Built-in MCU for intelligent processing
- ✓ Flexible configuration
- ✓ Programmable via Modbus over RS485
- ✓ Switchable interfaces: RS485, I2C, and SPI
- ✓ High accuracy up to $\pm 0.03\%$ FS (TEB)
- ✓ Integrated high-precision temperature sensor ($\pm 0.1^\circ\text{C}$)
- ✓ Supports low-power operation for embedded systems



Introduction

The GP-2710 Intelligent Pressure Sensor represents a new generation of pressure sensing technology, combining a traditional OEM sensor form factor with advanced digital processing capabilities. Unlike conventional digital pressure sensors based on ASIC architecture, the GP-2710 integrates a powerful onboard MCU, enabling enhanced flexibility, configurability, and performance.

Through Modbus communication, users can easily configure sensor parameters, switch communication interfaces, and adapt the sensor to different system requirements. The device supports RS485, I2C, and SPI interfaces, allowing seamless integration into industrial networks as well as embedded platforms.

With proprietary compensation algorithms, the GP-2710 performs real-time temperature compensation and nonlinearity correction, achieving accuracy levels comparable to high-end pressure transmitters. At the same time, the integrated temperature sensor enables precise ambient monitoring.

Designed for modern applications, the GP-2710 supports low-voltage operation down to 3.2V and includes low-power modes, making it suitable for battery-powered and embedded systems. Its ability to combine sensing, processing, and communication in a single compact unit makes it an ideal solution for smart instrumentation, industrial automation, and next-generation IoT systems.

Specification

Items	Parameters
Range	-100kPa…0 ~ 20kPa…70MPa
Pressure Type	Gauge, Absolute, Sealed gauge
Overload	x2 FS or 110MPa (Take minimum value)
TEB ¹ (Total Error Band)	±0.1%FS, ±0.05%FS, ±0.03%FS
Compensation Temp.	-10°C ~ 70°C
Operating temp.	-30°C ~ 80°C
Storage Temp. ²	-40°C ~ 105°C
Power Supply	1.8VDC~ 36VDC
Communication	RS485 (Modbus RTU, 1200, 2400, 4800, 9600(Default), 19200, 38400)
Output Mode	RS485 Slave & I ² C Slave & SPI Slave / SPI Streaming
Working Current	Typ. 1.7mA standard power mode Typ. 6.5uA Standby low power mode
Temp. Accuracy ³	< ±0.1°C (0°C ~ 50°C) , < ±0.2°C (-10°C ~ 60°C) , < ±0.5°C (-25°C ~ 75°C)
Response Time ⁴	50ms, standard power mode <300ms, low power mode
Sample Frequency ⁴	20Hz (Default), can be set at 5Hz, 50Hz, 100Hz
Insulation resistance ⁵	100MΩ, 100VDC
Vibration	No change, 10gRMS, (20~2000)Hz
Impact	100g, 11ms
Position Effect	deviate 90° from any orientation, zero change ≤0.05%FS
Lifetime	≥10 million cycles
Long-term stability	±0.1% FS/year
Media compatibility	The gas or liquid which is compatible with stainless steel and FKM
Protection	IP65, Circuit board black epoxy potting. (Not including connector)
Materials	Housing & Diaphragm: 316L Stainless steel O-ring: Viton Filled oil: Silicon oil
Cable	2651 26AWG Flat cable, 105°C, 155mm
Connector	ZH1.5-7P connector
Net weight	≈ 23g
Note:	<ol style="list-style-type: none"> Including calibration error and temperature drift effects. It can be up to 125°C without flat cable. Onboard ambient/reference temperature. Increasing the sampling rate may lose some precision and affect response time.

5. Insulation resistance was tested under $RH \leq 65\%$ and $Temp. \leq 35\text{ }^\circ\text{C}$

Dimensions (mm)

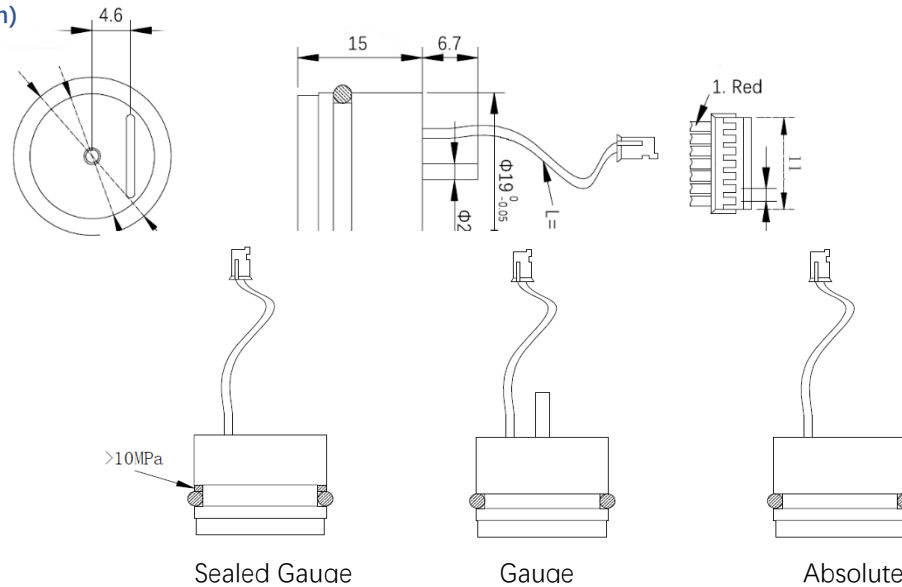

Electrical connection

Working Mode

Mode	Standard					Low Power			
Code	0x00	0x01	0x02	0x03	0x04	0x10	0x11	0x12	0x13
Interface 1	RS485					Low Power RS485			
Interface 2	/	I2C Slave	SPI Slave	SPI Streaming	Reserve	/	I2C Slave	SPI Slave	SPI Streaming

Wires Definition

No.	Definition	Description
1 (Red)	V+	VCC
2	V-	GND
3	DATA	<ul style="list-style-type: none"> In 0x00 and 0x10 modes, this pin may be left floating. In other modes, an external pull-up resistor must be used to pull the pin up to 3.3V; a resistance of 10kΩ is recommended. In I²C slave mode, this pin functions as the SDA pin. In SPI slave mode, after the data-ready signal has been output as a low-level pulse, it functions as the MISO pin. In SPI Streaming mode, it functions as the MOSI pin.
4	CLK	<ul style="list-style-type: none"> In 0x00 and 0x10 modes, this pin may be left floating. In other modes, an external pull-up resistor must be used to pull the pin up to 3.3V; a resistance of

		<p>10kΩ is recommended.</p> <ul style="list-style-type: none"> · In I²C slave mode, this pin functions as the SCL pin. · In SPI mode, this pin functions as the SCLK pin.
5	CS/INT	<ul style="list-style-type: none"> · In 0x00 and 0x10 modes, this pin may be left floating. In other modes, an external pull-up resistor to 3.3V is required; a resistance of 10 kΩ is recommended. · I²C interrupt pin. In I²C mode, a low-level pulse is generated when data is ready. · SPI chips select pin.
6	RS485-A	Leave it floating if not in use, it is recommended to reserve a connection point.
7	RS485-B	

Application 1: Sensor imbedded in device

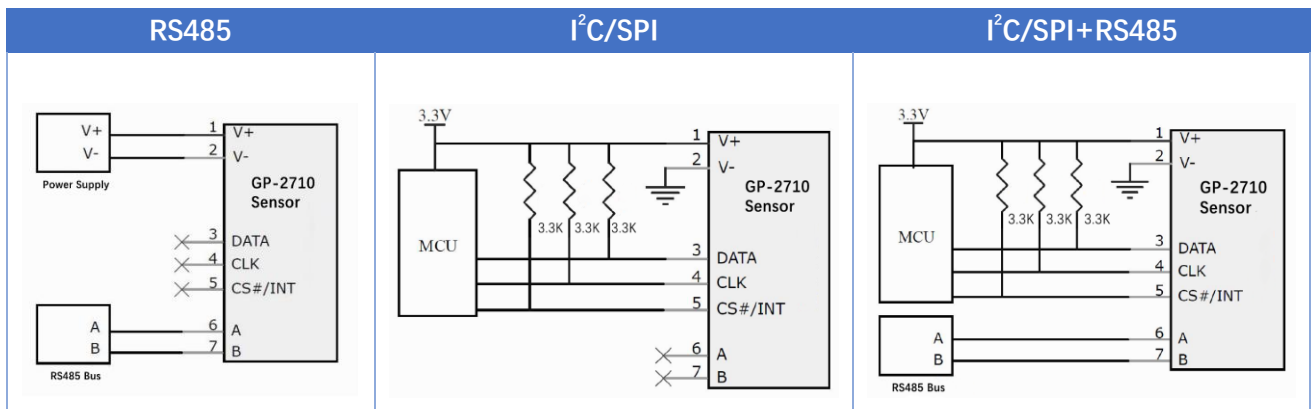



1: Simultaneously acquiring pressure values via I²C/SPI and RS485 may affect response speed; however, it is still recommended to retain the RS485 connection points to allow for full-function calibration of the digital sensor in the future.

2: If the digital sensor is used as a standalone product in an RS485 application, it is necessary to include EMC protection components in the circuit to enhance resistance to electromagnetic interference such as static electricity, burst noise, and surges.

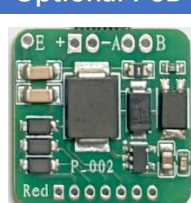
Application 2: Sensor to transmitter

Type	Optional PCB	Function	Note
GP-2710-P RS485Digital Transmitter		Output: RS485 Modbus Power supply: 3.3~28VDC Size: 20x20mm EMC	/

<p>GP-2710-Io</p> <p>4~20mA Transmitter</p>		<p>Output: two wires 4~20mA Power supply: 8~28VDC Calibration: temp. by software Size: 20x20mm EMC</p>	<p>The sensor must be set to Hp_lout mode</p>
<p>GP-2710-Vo</p> <p>0.5~2.5/4.5V 0~5/10V 1~5/10V Transmitter</p>		<p>Zero Output: 0~2VDC Full Output: 2.5~10VDC Calibration: temp. by software Size: 20x20mm EMC</p>	<p>The sensor must be set to Hp_Vout mode; Voltage switching requires the removal or replacement of some onboard resistors; There will be an output of a few mV at zero.</p>

Configuration Software

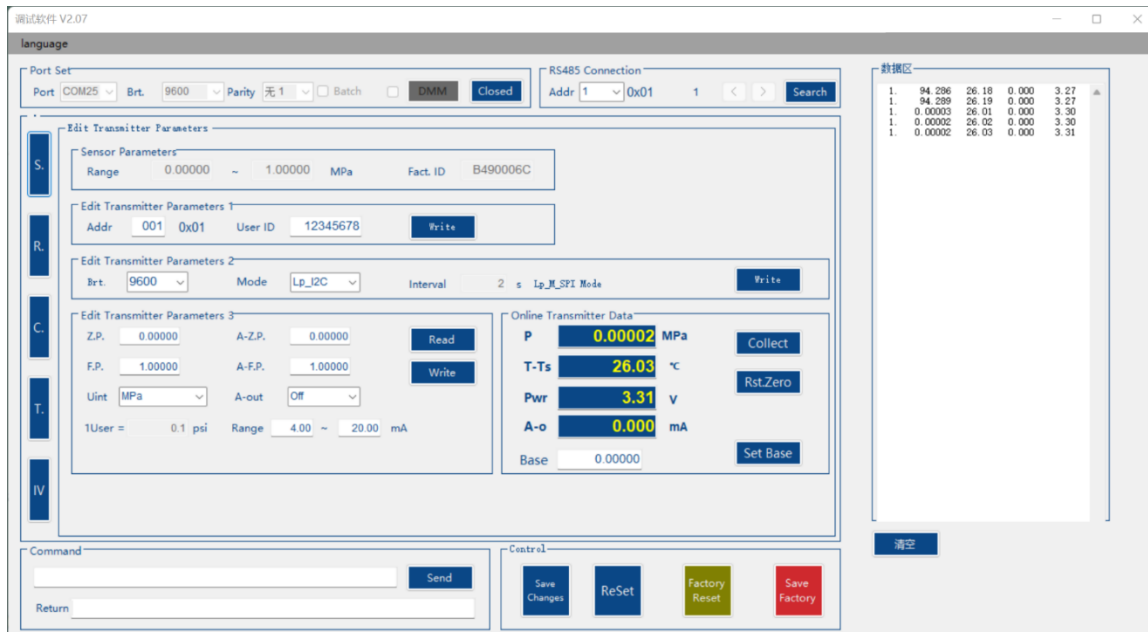

Dedicated configuration software that reads sensor data, configures basic parameters, adjusts measurement ranges, switches units, and performs many other functions via the RS485 interface. There's a hide function for current and voltage calibration when sensor connects to transfer PCB.

1. Operating Instructions: Connect the USB-to-RS485 module to your computer, connect the product to the RS485 module, and power on the product.

Open the software, select the corresponding serial port and baud rate (the default for this product is 9600), click the "Open" button, then click the "Search" button until the number of devices online is 1. Click the "Stop" button. The software will automatically read the digital sensor parameters.

2. In the "Parameter Modification" section, you can change the address and baud rate. The address can be set between 1 and 240, and the baud rate can be set to 1200, 2400, 4800, 9600, 19200, or 38400. After entering the address or selecting the baud rate, press the "Modify" button for the changes to take effect immediately. Rescan for the product to confirm the information is correct and click "Save Changes" to ensure the modifications are retained after power is lost.

3. You can modify the operating mode. After selecting the desired mode, click the "Modify" button, then click "Save Changes," and wait for the sensor to automatically save the settings before they take effect (approximately 3–5 seconds).

4. The sensor has 36 built-in pressure units that can be switched via the software.

5. Ambient temperature refers to the temperature data output by the high-precision temperature sensor.

6. The offset setting allows you to shift the sensor's output; the output value = measured value – offset.

7. When executing commands, the software performs a built-in CRC check, eliminating the need for the user to calculate or enter it.

Order Guide

GP-2710 Programmable Pressure Sensor						
	Code1	Pressure Range				
	0B	0~20kPa	G	12	0~2MPa	G/A
	0A	0~35kPa	G	13	0~3.5MPa	G/A
	02	0~70kPa	G/A	14	0~7MPa	A/S
	03	0~100kPa	G/A	15	0~10MPa	A/S
	07	0~200kPa	G/A	17	0~20MPa	A/S
	08	0~350kPa	G/A	18	0~35MPa	A/S
	09	0~700kPa	G/A	19	0~70MPa	A/S
	10	0~1MPa	G/A			
		[X-Y]kPa/MPa	Only using for customized range			
		Code2	Pressure Type			
		G	Gauge			
		A	Absolute			
		S	Sealed Gauge			
			Code3	Accuracy		
			S	±0.03%FS (>100kPa G or ≥200kPa A)		
			A	±0.05%FS		
			B	±0.1%FS		
				Code4	Cable Length	
				L150	150mm (Default)	
				LXXX	Customized Length	
GP-2710	03	G	B	L150		

Completed Sample: **GP-2710-03-G-B-L150**

Optional PCB

An optional transfer circuit board is available, providing current, voltage, or RS485 outputs with full EMC protection. There're 3 options for choice.

- GP-2710-P RS485 Modbus
- GP-2710-Io 4~20mA
- GP-2710-Vo 0~5VDC (Default)

Tips:

The sensor diaphragm is extremely fragile. Any direct contact with hard objects may cause diaphragm deformation and damage to the sensor.

Communication reference

1 RS485 Guide

1.1 Overview

The RS485 interface can be used with the digital sensor in any mode. When using only the RS485 interface and the CLK, DATA, and CS/INT pins do not have pull-up resistors, ensure that the digital sensor is in 0x00 or 0x10 mode.

Communication uses the standard MODBUS RTU protocol; this device acts as a slave and supports networking with up to 240 units.

Character format: 1 start bit, 8 data bits, 1 stop bit, no parity bit.

Supported commands: Read (03), Write Single Register (06), Write Multiple Registers (10).

CRC check: 16-bit CRC check, with the low byte first and the high byte last.

Address 00 is the universal address.

1.2 Examples of Commands

Pressure Read Command: Addr + 0x03 + 0x00 + 0x02 + 0x00 + 0x02 + CRCL + CRCH

Response: Addr + 0x03 + 0x04 + 0xCC + 0xDD + 0xAA + 0xBB + CRCL + CRCH

Pressure value: The retrieved pressure data is of type float or long, with byte order CDAB

Example 1 Send: 01 03 00 02 00 02 65 CB Response: 01 03 04 42 31 3F A8 AF CA

The pressure value is 0x3FA84231 (float type), which equals 1.314520 in decimal

Example 2: Modify address 02

Command: 01 06 00 01 00 02 59 CB Response: 02 06 00 01 00 02 59 F8

1.3 Special Commands

Save data to user area: Addr + 0x10 + 0xF1 + 0xAA + 0x11 + 0x33 + 0x55 + CRCL + CRCH

Restore factory settings: Addr + 0x10 + 0xF3 + 0xAA + 0x11 + 0x33 + 0x55 + CRCL + CRCH

Reset: Addr + 0x10 + 0xB0 + 0xAA + 0x11 + 0x33 + 0x55 + CRCL + CRCH

1.4 Register Definition

Register Start	Bytes	Definition	Date Type	Note
001 / 0x01	1 / 2	Sensor Address	Short	Default 0x01, 0x01~0xEF
002 / 0x02	2 / 4	Pressure	Float	Realtime Pressure
006 / 0x06	2 / 4	Temperature °C	Float	Temperature sensor output
010 / 0x0A	2 / 4	Voltage V	Float	Power supply
028 / 0x1C	2 / 4	Pressure	Long	Realtime Pressure
030 / 0x1E	1 / 2	Decimal	Short	Decimal digits

032 / 0x20	1 / 2	Unit	Short	Unit, refer to "Unit Definition"
034 / 0x22	1 / 2	Sampling Rate	Short	1 (20 times/sec, default) 0 (5 times/sec), 2 (50 times/sec) , 3 (100 times/sec)
035 / 0x23	1 / 2	Mode	Short	Refer to "Electrical Connection-Working Mode"
042 / 0x2A	1 / 2	Temp. Switch	Short	Temperature switch, 0-Off / 1-On
060 / 0x3C	2 / 4	Interval	u-Long	Sample time, unit second
064 / 0x40	1 / 2	Baud rate	Short	Refer to "Baud Rate"
080 / 0x50	4 / 8	Serial No.	Char	
100 / 0x64	2 / 4	Zero Value	Float	Transmitter zero pressure
102 / 0x66	2 / 4	Full value	Float	Transmitter full pressure
104 / 0x68	2 / 4	Analog Zero	Float	Set transmitter's zero
106 / 0x6A	2 / 4	Analog Full	Float	Set transmitter's full
108 / 0x6C	2 / 4	Offset	Float	Measure value-drift value

1.5 Unit Definition

Unit Register	Unit	Psi-Unit (Psi*N)	Unit-Psi (Unit*N)	Formal Unit
00 / 0x00	Pa	6894.757	0.000145038	pascals
01 / 0x01	hPa	68.94757	0.01450377	hectopascals
02 / 0x02	kPa	6.894757	0.1450377	kilopascals
03 / 0x03	MPa	0.006894757	145.0377	megapascals
04 / 0x04	mBar	68.94757	0.01450377	millibars
05 / 0x05	Bar	0.06894757	14.50377	bars
06 / 0x06	mTorr	51715.08	1.93367E-05	millitorr
07 / 0x07	Torr	51.71508	0.01933672	torr
08 / 0x08	PSI	1	1	pounds per square inch
09 / 0x09	Dy/cm2	68947.57	1.45038E-05	dyne per square centimeter
10 / 0x0A	gm/cm2	70.30697	0.01422334	grams per square centimeter
11 / 0x0B	kg/cm2	0.07030697	14.22334	kilograms per square centimeter
12 / 0x0C	PSF	144	0.006944444	pounds per square foot
13 / 0x0D	OSI	16	0.0625	ounce per square inch
14 / 0x0E	TSF	0.072	13.88889	tons per square foot
15 / 0x0F	TSI	0.0005	2000	ton per square inch
16 / 0x10	mmH2O 4°C	703.089	0.001422295	millimeters of water @ 4°C
17 / 0x11	cmH2O 4°C	70.3089	0.01422295	centimeters of water @ 4°C
18 / 0x12	inH2O 4°C	27.68067	0.03612629	inches of water @ 4°C
19 / 0x13	ftH2O 4°C	2.306726	0.4335149	feet of water @ 4°C
20 / 0x14	MH2O 4°C	0.703089	1.422295	meters of water @ 4°C

21 / 0x15	mmH2O 20°C	704.336	0.001419777	millimeters of water @ 20°C
22 / 0x16	cmH2O 20°C	70.4336	0.01419777	centimeter of water @ 20°C
23 / 0x17	inH2O 20°C	27.72977	0.03606233	inches of water @ 20°C
24 / 0x18	ftH2O 20°C	2.310814	0.432748	feet of water @ 20°C
25 / 0x19	MH2O 20°C	0.704336	1.419777	meters of water @ 20°C
26 / 0x1A	inH2O 60°F	27.70759	0.03609119	inches of water @ 60°F
27 / 0x1B	ftH2O 60°F	2.308966	0.4330943	feet of water @ 60°F
28 / 0x1C	inSW 0°C 3.5% salinity	26.92334	0.0371425	inches seawater @ 0°C 3.5% salinity
29 / 0x1D	ftSW 0°C 3.5% salinity	2.243611	0.44571	feet seawater @ 0°C 3.5% salinity
30 / 0x1E	MSW 0°C 3.5% salinity	0.6838528	1.462303	meters seawater @ 0°C 3.5% salinity
31 / 0x1F	μHg 0°C	51715.08	1.93367E-05	micron HG @ 0°C
32 / 0x20	mmHg 0°C	51.71508	0.01933672	millimeters of mercury @ 0°C
33 / 0x21	cmHg 0°C	5.171508	0.1933672	centimeters of mercury @ 0°C
34 / 0x22	inHg 0°C	2.03602	0.4911544	inches of mercury @ 0°C
35 / 0x23	inHg 60°F	2.041772	0.4897707	inches of mercury @ 60°F
36 / 0x24	ATM	0.06804596	14.69595	atmospheres
37 / 0x25	User			customized, default 1user=10psi

1.6 Baud Rate

Addr	Baud
0 / 0x00	1200
1 / 0x01	2400
2 / 0x02	4800
3 / 0x03	9600
4 / 0x04	19200
5 / 0x05	38400

1.7 CRC Verify Code Program Reference

```
uint16_t crc_val[2]={0};
void crc16(uint8_t *ptr,uint8_t len2)
{
    uint16_t temp,wcrc=0xFFFF, i=0, j=0;
    for(i=0;i<len2;i++)
    {
        temp=*ptr&0x00FF;
        ptr++;
        wcrc^=temp;
    }
}
```

```
    for(j=0;j<8;j++)
    {
        if(wcrc&0x0001)
        {
            wcr<>>=1;
            wcr^=0xA001;
        }
        else
        {
            wcr<>>=1;
        }
    }
}
crc_val[0]=(wcr<&0x00ff);
crc_val[1]=wcr<>>8;
}
```

2 I²C Guide

2.1 Overview

Digital sensors use the SDA and SCL pins to implement the I²C bus communication protocol. Each transmission sequence begins with a START condition (S) and ends with a STOP condition (P), as described in the I²C bus specification. The slave I²C address is 7 bits long, with a default value of 0x40.

2.2 Read and Write Rules

In I²C bus communication, the master first transmits the slave address and the write-flag (Slave Address + W), followed immediately by the register logical address (Register Address). For reading operations, the master then transmits the slave address and the read-flag (Slave Address + R) again, after which the slave sends data to the master (Data from Register). Multiple slave register data can be read sequentially in this manner; For the write sequence, the master then sends data directly to the slave (Data to Register). Note that the slave address is 7 bits wide. Write-flag W=0, read-flag R=1. The specific read and write timing diagrams are as follows:

Read Operation

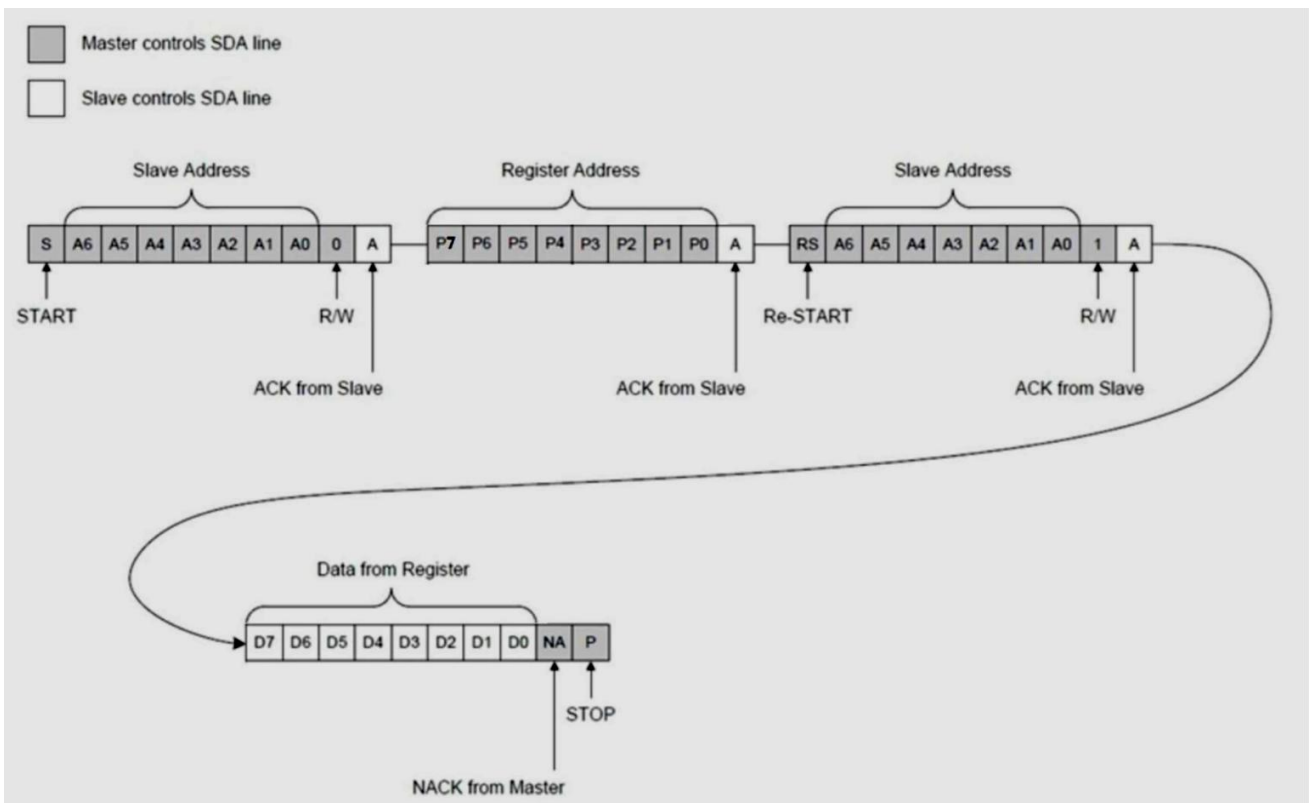

Write Operation

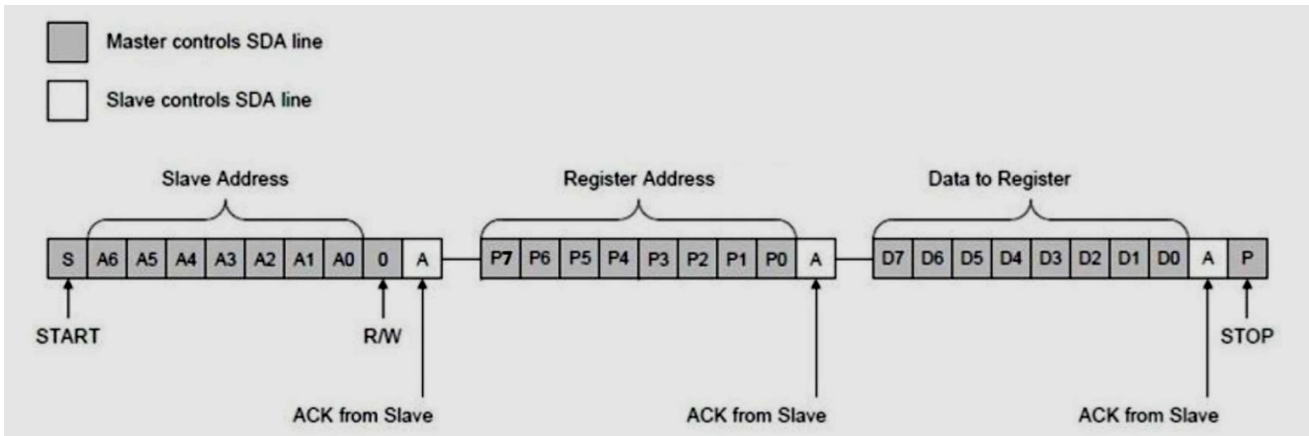

When reading from a register, the host can read the data from the parity register to verify the accuracy of the transmitted data and check specific fields.

2.3 Interface Operations

2.3.1 Under normal power consumption conditions, the digital sensor continuously collects data. After each data collection cycle is complete and the register data is updated, the INT pin outputs a low level. Users can read the data at any time as needed, or read it based on the INT interrupt signal. When reading collected data, it is recommended to read the 13 bytes of data from registers 00 to 12 consecutively and read the checksum to verify that the data was transmitted correctly.

2.3.2 In low-power mode, the digital sensor is in a sleep state. The user can wake up the sensor for data acquisition by writing 0x11 to register 0x1D. Once data acquisition is complete and the register data has been updated, the INT pin will output a low level. The user can read the data after a delay of more than 300 ms, or read it based on the INT low-level signal.

2.3.3 Software reset. The user can write 0x55 to register 0x1D, followed immediately by writing 0xB0 to register 0x1D, to perform a software reset on the digital sensor.

2.3.4. Saving User Settings. The user can write 0x55 to register 0x1D, followed by writing 0xF1 to register 0x1D, to save modified user data and prevent loss due to power failure. This is commonly used for modifying pressure units and offsets.

2.3.5 External Reset. In I²C slave, SPI slave, and SPI Streaming modes, pull the CS and DATA pins low while keeping the CLK pin high. After approximately 500 ms, the digital sensor will restart.

2.4 Register Definition

Register Start	Bytes	Definition	Date Type	Note
00 / 0x00	4	Pressure	Float	Real-time digital pressure output
04 / 0x04	4	Temperature °C	Float	Temperature sensor output
08 / 0x08	4	Voltage V	Float	Power supply voltage
12 / 0x0C	1	Verify Code	uChar	00-12 Verify code of register
16 / 0x10	4	Zero Pressure	Float	Sensor zero pressure value
20 / 0x14	4	Full Pressure	Float	Sensor full pressure value
24 / 0x18	4	Offset	Float	Measure value-drift value
28 / 0x1C	1	Unit	uChar	Pressure Units
29 / 0x1D	1	Mode	uChar	
30 / 0x1E	1	Verify Code	uChar	16-28 verify code of register

Note: In the table, the byte order for Float data is low-byte first, high-byte last.

2.5 Verify Code Demonstration

```
uint8_t CRC8MY(uint8_t *serial, uint8_t length)
```

```
{
    uint8_t result = 0x00;
    uint8_t pDataBuf;
    uint8_t i;
    while(length--)
    {
        pDataBuf = *serial++;
        for(i=0; i<8; i++)
        {
            if((result^(pDataBuf))&0x01)
            {
                result ^= 0x18;
                result >>= 1;
                result |= 0x80;
            }
            else
            {
                result >>= 1;
            }
            pDataBuf >>= 1;
        }
    }
    return result; //返回校验和
}
```

3 SPI Slave Mode Guide

3.1 Overview

In this mode, the digital sensor acts as a three-wire SPI slave and performs only data output; SPI operates in Mode 3 (CPOL=1, CPHA=1).

3.2 Reading Rules

After the DATA pin outputs a low-level pulse to indicate data readiness, it functions as the SPI data output (MISO pin); the SCK pin serves as the SPI clock input (SCLK pin); and the CS/INT pin acts as the SPI chip select input (CS pin), while also being used for wake-up in low-power mode.

3.3 Interface Operation

3.3.1. Under normal power consumption conditions, the digital sensor continuously performs data acquisition. After each data acquisition is completed and the register data is updated, the DATA pin outputs a low-level pulse. Users may choose whether to read the data as needed. It is recommended to continuously read the 13 bytes of data from register 00 to 12 and read the checksum to verify that the data has been transmitted correctly.

3.3.2 In low-power mode, the digital sensor is in sleep mode. The user can send a low-level pulse to the CS/INT pin to wake up the sensor for data acquisition. Once data acquisition is complete and the register data is updated, the DATA pin will output a low level. After the user reads the data or approximately 200 ms after data conversion is complete, the digital sensor automatically enters sleep mode. The user may read the data after a period of more than 300 ms following wake-up or based on the low-level signal on the DATA pin.

3.3.3 External Reset. In I²C slave, SPI slave mode, and SPI Streaming modes, pulling the CS and DATA pins low while keeping CLK high for approximately 500 ms will cause the digital sensor to reboot.

3.3.4 Register Definition

Register Start	Bytes	Definition	Date Type	Note
00 / 0x00	4	Pressure	Float	Real-time digital pressure output
04 / 0x04	4	Temperature °C	Float	Temperature sensor output
08 / 0x08	4	Voltage V	Float	Power supply voltage
12 / 0x0C	1	Verify Code	uChar	00-12 Verify code of register

Note: In the table, the byte order for Float data is low-byte first, high-byte last.

3.4 Verify Code Programming (Refer to 2.5)

4 SPI Streaming Guide

4.1 Overview

In this mode, the digital sensor acts as a three-wire SPI streaming and performs only data output; SPI operates in Mode 3 (CPOL=1, CPHA=1).

4.2 Reading Rules

The DATA pin serves as the SPI data output (MOSI), the SCK pin serves as the SPI clock input (SCLK), and the CS/INT pin serves as the SPI chip select (CS) output.

4.3 Interface Operation

4.3.1 Under normal power consumption, the digital sensor continuously collects data. After each data collection cycle is complete and the register data is updated, it actively transmits 13 bytes of data from registers 00 to 12 to the SPI bus. The user receives the data and compares it with the checksum to verify that the data was transmitted correctly.

4.3.2 In low-power mode, the digital sensor is in a sleep state. At set time intervals, the sensor is periodically awakened to perform data acquisition. Once data acquisition is complete and the register data is updated, it actively transmits 13 bytes of data from registers 00 to 12 to SPI bus. The digital sensor then automatically returns to sleep mode. The user receives the data and compares it with the checksum to verify that the data was transmitted correctly.

4.3.3 External Reset. In I²C slave, SPI slave, and SPI streaming modes, pull the CS and DATA pins low while keeping the CLK pin high. After approximately 500 ms, the digital sensor will perform a restart operation.

4.3.4 Register Definition

Register Start	Bytes	Definition	Date Type	Note
00 / 0x00	4	Pressure	Float	Real-time digital pressure output
04 / 0x04	4	Temperature °C	Float	Temperature sensor output
08 / 0x08	4	Voltage V	Float	Power supply voltage
12 / 0x0C	1	Verify Code	uChar	00-12 Verify code of register

Note: In the table, the byte order for Float data is low-byte first, high-byte last.

4.4 Verify Code Programming (Refer to 2.5)